

Чертежи и монтажные позиции червячных мотор-редукторов серии XC

**XA**

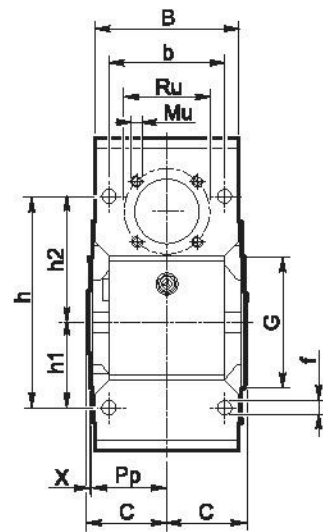

**XF**

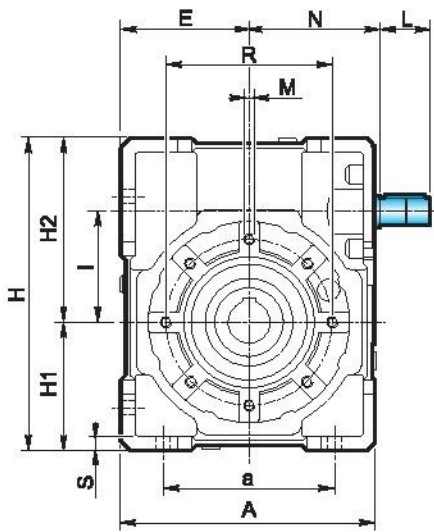
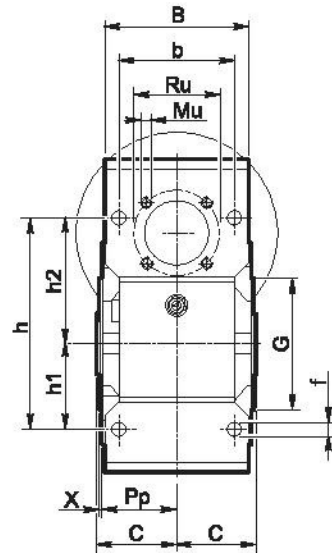
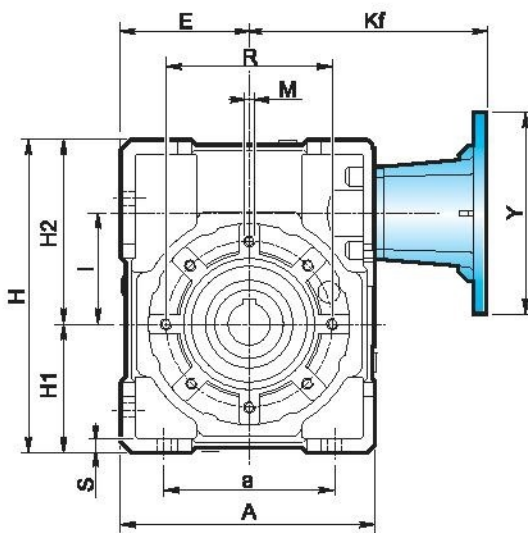

**XC**

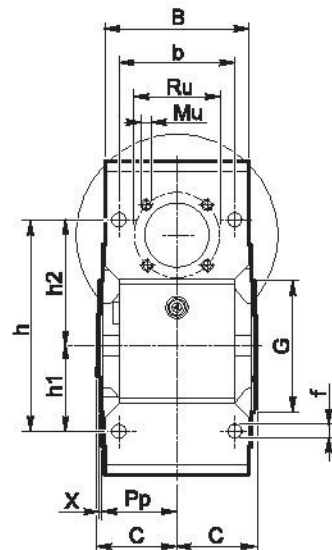
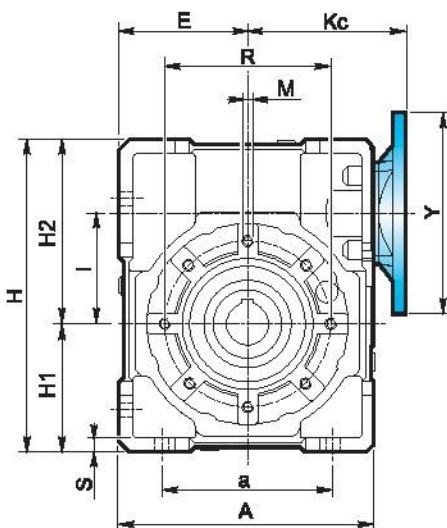

Чертежи и монтажные позиции червячных мотор-редукторов серии XC

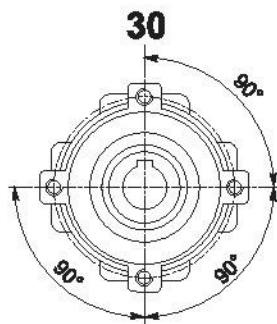

4 Fori / Holes / Bohrungen

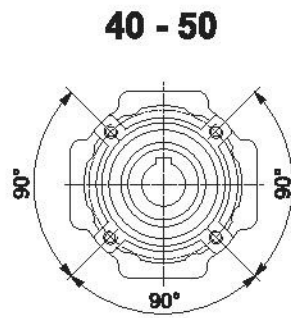

4 Fori / Holes / Bohrungen

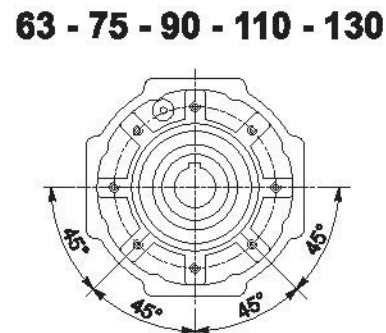

8 Fori / Holes / Bohrungen

Albero uscita cavo  
Output hollow shaft  
Abtriebshohlwelle

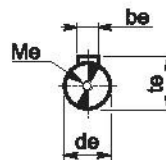
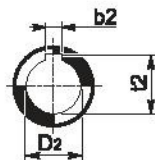

Albero entrata  
Input shaft  
Antriebswelle

X	A	a	B	b	b <sub>0</sub>	b <sub>2</sub>	C	d <sub>6</sub>	D <sub>2</sub> H7	E	f	G h8	H	H <sub>1</sub>	H <sub>2</sub>	h	h <sub>1</sub>	h <sub>2</sub>		
30	80	54	56	44	3	5	—	31.5	9	14	—	40	6.5	55	97	40	57	71	27	44
40	105	70	71	60	4	6	6	39	11	18	19	50	6.5	60	125	50	75	90	35	55
50	125	80	85	70	5	8	8	46	14	25	24	60	8.5	70	150	60	90	104	40	64
63	147	100	103	85	6	8	—	56	19	25	—	72	9	80	182	72	110	130	50	80
75	176	120	112	90	8	8	8	60	24	28	30	86	11	95	219.5	86	133.5	153	60	93
90	203	140	130	100	8	10	—	70	24	35	—	103	13	110	248.5	103	145.5	172	70	102
110	252.5	170	143	115	8	12	—	77.5	28	42	—	127.5	14	130	310.5	127.5	183	210	85	125
130	292.5	200	155	120	10	14	14	85	38	48	45	147.5	15	180	355	147.5	207.5	240	100	140

X	I	K <sub>c</sub>	K <sub>f</sub>	L	M	M <sub>c</sub>	M <sub>u</sub>	N	P <sub>p</sub>	R	R <sub>u</sub>	S	t <sub>c</sub>	t <sub>2</sub>	X	
30	31.5	57	vedi pag. see page siehe S. 32	15	M6x8	M4x10	M5x7.5	44.5	29	85	35.4	5.5	10.2	16.3	—	1.5
40	40	75		20	M6X10	M4X12	M5X10	57.5	36.5	75	42.4	6	12.5	20.8	21.8	1.5
50	50	82		25	M8x10	M5x13	M6x10	67.5	43.5	85	53.7	7	16	28.3	27.3	1.5
63	63	95		30	M8x14	M8x20	M6x12	77.5	53	95	60.8	8	21.5	28.3	—	2
75	75	112		40	M8x14	M8x20	M8x12	95	57	115	70.7	10	27	31.3	33.3	2
90	90	122		40	M10x18	M8x20	M8x14	105	67	130	70.7	12	27	38.3	—	2
110	110	153		50	M10x18	M8x20	M10x18	130	74	165	85.0	14	31	45.3	—	2.5
130	130	173		70	M12x20	M10x25	M10x16	152	81	215	104	15	41	48.8	51.8	3

# Чертежи и монтажные позиции червячных мотор-редукторов серии XC

Выходной фланец

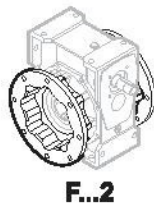
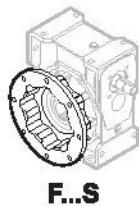
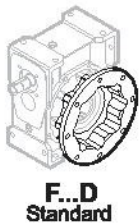
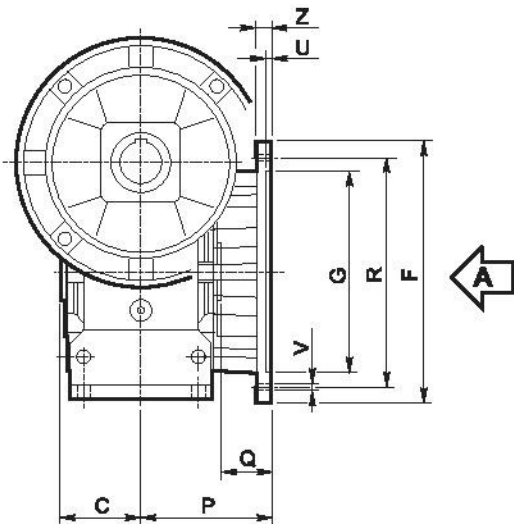

Vista da A / View from A / Ansicht von A

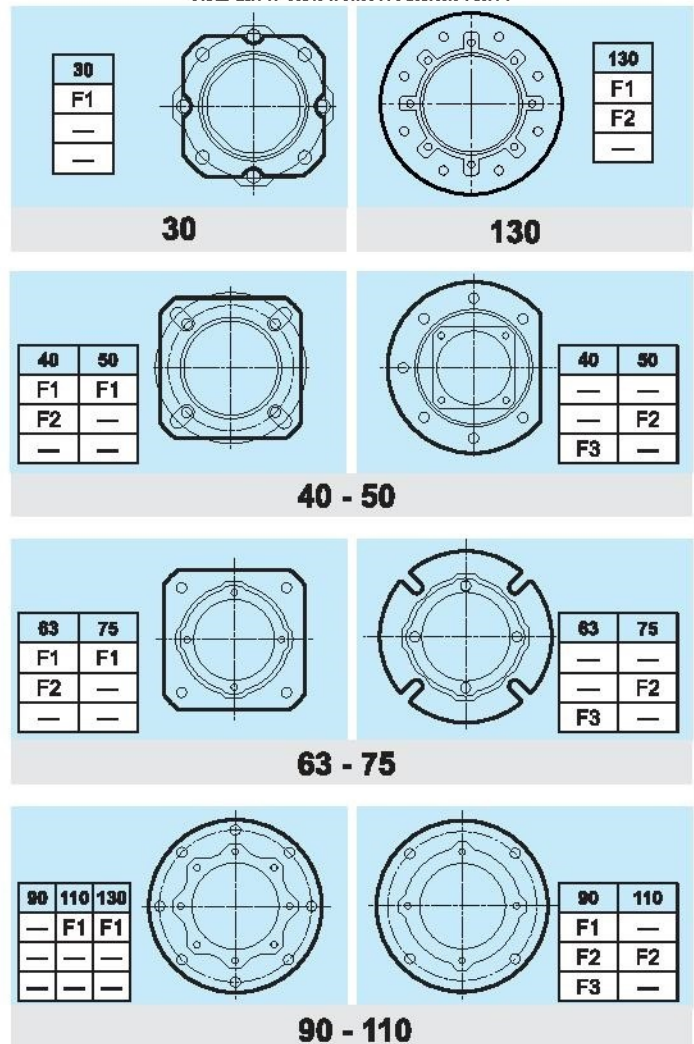

Тип Type Typ	C	F		G H8	P	Q	R	U	V			Z
<b>30</b>	31.5		88	50	54.5	23	68	4	n° 4		6.5	6
<b>40</b>	39		85	60	67	28	75-90	4	n° 4		9	8
			85	60	97	58	75-90	4	n° 4		9	8
		140	95	80	41	115	5		n° 7	9	10	
<b>50</b>	46		94	70	90	44	85-100	5	n° 4		11	10
		160	110	89	43	130	5		n° 7	11	11	
<b>63</b>	56		142	115	82	28	150	5	n° 4		11	11
			142	115	112	56	150	5	n° 4		11	11
		160	110	80.5	24.5	130	5	n° 4		11	12	
<b>75</b>	60		160	130	111	51	165	5	n° 4		13	12
		160	110	80	30	130	6	n° 4		11	13	
<b>90</b>	70	200		152	111	41	175	5	n° 4		13	12
		200		152	151	81	175	5	n° 4		13	13
		200		130	110	40	165	6	n° 4		11	11
<b>110</b>	77.5	260		170	131	53.5	230	6		n° 8	13	15
		250		180	150	72.5	215	5	n° 4		15	16
<b>130</b>	85	320		180	140	55	255	7		n° 8 *	16	16
		300	230	265								

\* Foratura ruotata di 22.5°

\* Drilling turned of 22.5°

\* Durchbohrung 22.5° versetzt



